

# CRE



**4/83-87 Dolphin Street Coogee NSW**

**2 🛏 1 🚿 1 🚗**

Beach life is at the doorstep of this newly refreshed boutique apartment making it a perfect lifestyle purchase or fantastic low-maintenance investment. Set in a secure block of eight opposite Coogee Oval, this two-bedroom apartment captures gun-barrel views through the goal posts from its quiet rear setting and features a lock-up garage on title. Just 250m to Coogee Pavilion with the sand and surf at the end of the street, this neat and tidy apartment offers a relaxed easycare lifestyle, footsteps to beachside cafes and eateries and a scenic walk along the coast to Bronte and Bondi Beaches.

- + Laidback beachside living, secure block with low levies
- + Fresh paint and carpet, ready to move in or rent out
- + 2 peaceful double bedrooms, neat and tidy bathroom
- + Large living room with a balcony and Coogee Oval views
- + Eat-in gas kitchen, integrated laundry, share storage

**View** : <https://www.coogee realestate.com.au/sale/nsw/eastern-suburbs/coogee/residential/apartment/5903652>



**James Giltinan**  
**02 9665 3341**



**Ben Bartlett**  
**0499 828 091**

<https://www.coogee realestate.com.au>

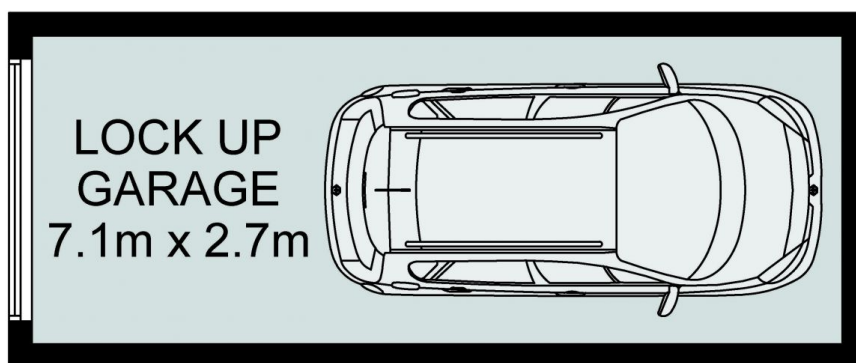
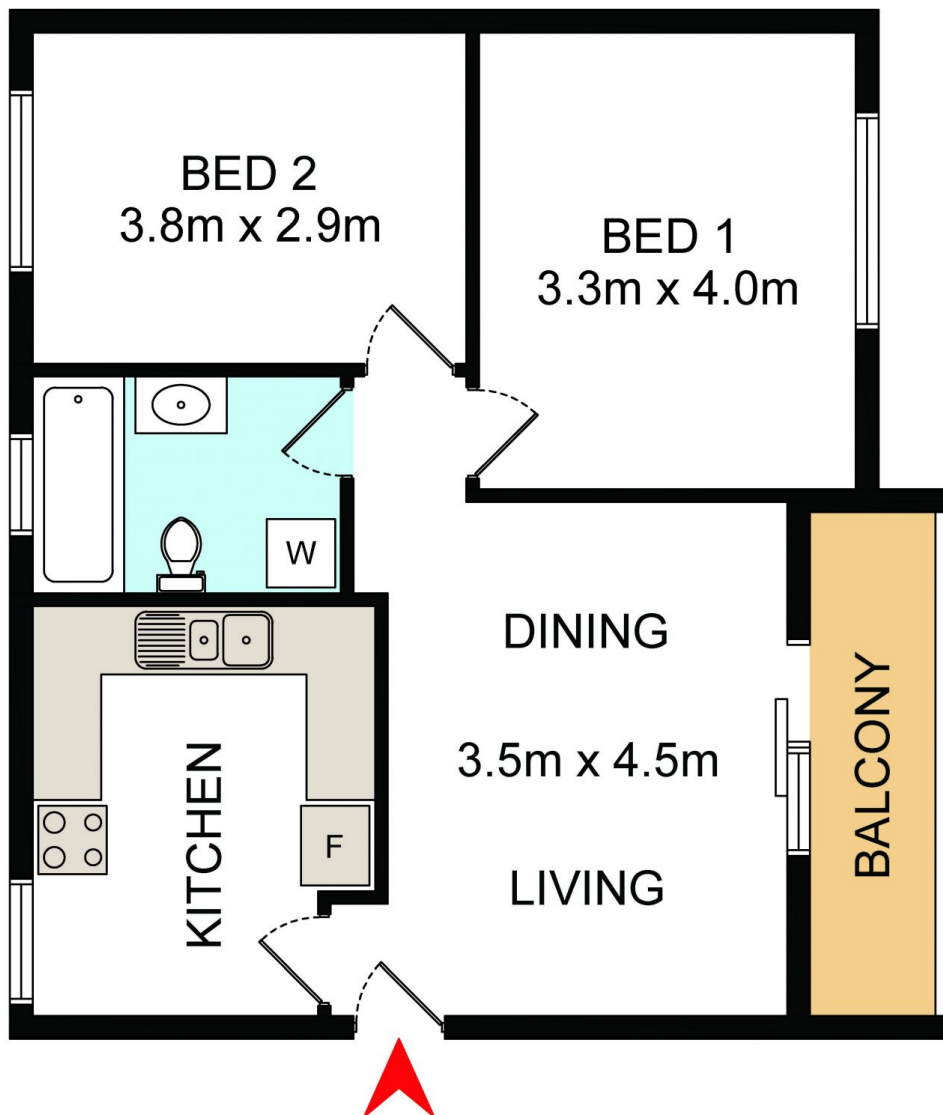

DISCLAIMER: THIS IS FOR ILLUSTRATIVE PURPOSES ONLY.  
ALL DIMENSIONS ARE APPROXIMATE AND IT DOES NOT  
CONSTITUTE PART OF ANY LEGAL DOCUMENTS.



4/83-87 Dolphin Street

Coogee